



Handling, Cutting, Glazing, Cleaning and Maintenance Information

HANDLING

Be careful not to damage the factory masking. Leave the masking on to protect the sheet until installed. If the masking has prolonged exposure to sunlight and moisture it could be difficult to remove. **Use plenty of help when lifting the sheet and to prevent scratching do not drag the sheet across a surface.**

CUTTING, SAWING, DRILLING & ROUTING

Use appropriate eye protection when operating equipment. Circular saws and table saws may be used with triple chip carbide blades with alternating bevel and straight teeth with approximately 3 teeth per inch. A hand-held saber saw may be used with blades designed for wood or composition board having 10 – 18 teeth per inch. Standard high-speed steel or carbide twist drills may be used but best results are done with a cutting tip angle reground to at least 160 degrees. **Drilled holes should be a minimum of 2 times the diameter of the screw from the edge of the regalGARD sheet.** Routing may be accomplished using two or three fluted carbide bits. Rough cut the area using a saber saw then perform a clean cut operation by using a router.

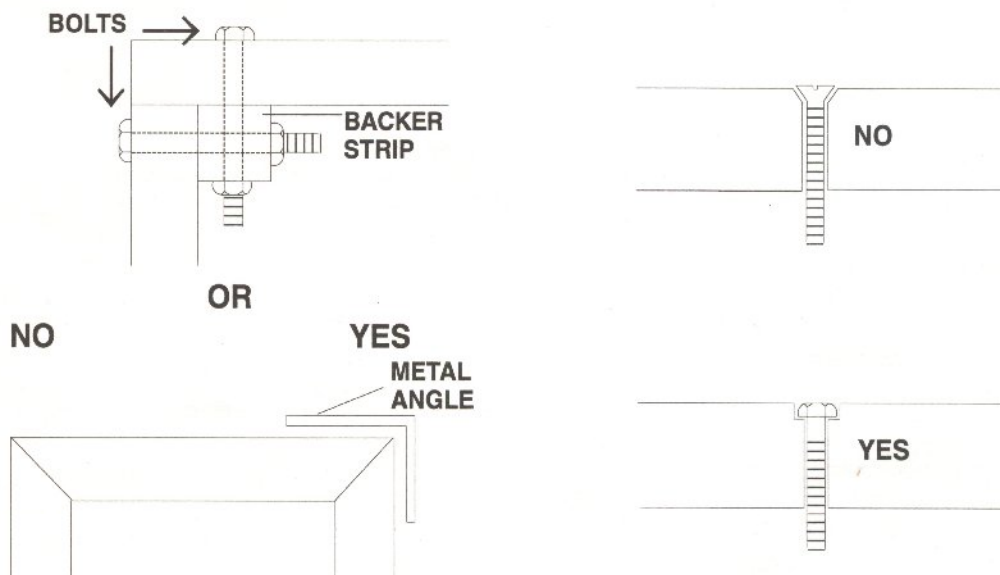



GLAZING INFORMATION

Warning Tape:

3/4” regalGARD has WARNING Tape to advise which side is the exterior – “This Side Out - Strike Side” The 1/8” thick Margard is the exterior / strike side. The 1/4” thick Margard is on the inside. 1-1/4” may be installed either side out.

Framing:

Structural security metal framing rated to the appropriate bullet resistant level is suggested. A minimum edge engagement of one (1) inch is recommended with allowances for material expansion (Large lites may require deeper engagements.)

Sealants and Gaskets:

The use of compatible sealant or gasket materials is recommended, with flexible material on both sides of the laminate. DO NOT use PVC gasket materials. DO NOT use setting blocks made from PVC, EPDM or neoprene rubber materials.

CLEANING AND MAINTENANCE INSTRUCTIONS

regalGARD Security Glazing uses the Lexan MR101 sheet on both sides of the laminated product. This Mar and UV resistant sheet will provide many years of service with periodic cleaning using proper procedures and compatible cleaners.

Cleaning Procedures: For general cleaning-

1. Wash with a mild solution of soap or detergent and lukewarm water.
2. Using a soft cloth or sponge, gently wash the sheet to loosen dirt and grime and rinse well with clean water.
3. To prevent water spotting, thoroughly dry with chamois or cellulose sponge.
4. Avoid the use of abrasive cleaners, squeegees and/or other cleaning implements that may mar or gouge the coating.

Compatible Cleaners:

Aqueous Solutions of Soaps and Detergents: Windex, Joy, Fantastik, Top Job, Mr. Clean, Formula 409

Organic Solvents: Naphtha (VM&P grade), Turco 5042, Butyl Cellosolve,

Alcohols: Methanol and Isopropyl Alcohol with a secondary rinse

Graffiti Removal:

For removal of paints, marking pen, inks, lipstick use butyl cellosolve. The use of masking tape, adhesive tape or lint removal tools work well for lifting off old weathered paints.

To remove labels and stickers the use of kerosene or VM&P Naphtha is generally effective. When the solvent will not penetrate the sticker material, apply heat from a hair dryer to soften the adhesive and promote removal.